



who provides laser  
marking solutions for  
every print process?

**we do. SunLase™**

**working for you.**

**SunChemical®**

a member of the DIC group



# Sales Information Sheet

SunLase™ laser marking inks from Sun Chemical are a range of specialised ink solutions based on Datalase® pigment, which contains absorbers and polymer technology, to allow a variety of different substrates to be marked, in line, with CO<sub>2</sub> laser technology.

## INTRODUCING SUNLASE LASER MARKING SOLUTIONS

SunLase inks are formulated to change from white to black when hit by a low energy laser – no burning, ablation or etching is involved – only a chemical reaction to the laser's application.

The new SunLase range offers packers and end users the platform to introduce greater efficiencies and productivity to their variable printing process, as well as higher quality on their identification marking applications.

### The benefits:

- Packaging products can be nominally patch printed to allow variable data to be marked and coded as required
- Reduction of SKU's and significant waste reduction through production of standard packaging that can then be marked and coded at the point of packing and filling rather than multiple runs of individual SKU packs
- No resetting of equipment for different jobs
- No consumables – packs are pre patch printed and then laser marked – no inks, ribbons etc at the point of print
- Excellent marking quality at high speeds
- Cost savings and flexibility are achieved by removing the need for secondary applications
- Inks are available for all substrates and print processes
- Ideal for packer fillers and printer converters who suffer fines for poor barcode quality
- Ideal for businesses looking seriously at packaging innovations and environmental issues.

### Additional comments

- The coatings are highly receptive and require little of the laser's available power to change from white to black
- Human & machine readable text and graphics can be printed at very high speeds
- 2D Data matrix codes can be printed at very high speed – 500 units per minute on milk container labels for example
- The application of varnishes and lacquers over the ink can further protect the code
- The colour change is light fast and is tolerant to most environmental stresses

## At a Glance

### Where can SunLase be used?

All packaging printers/converters or packing companies

- All flexible packaging
- Corrugated board applications
- Folding cartons
- PE Films
- Reverse-printed sleeves and plastic labels
- Multiwall sacks
- Liquid cartons

### What can be printed?

- Sequential numbers per pack / batch...
- Unique identifiers per pack, batch, consumer...
- Personalized data
- Network based coding
- Primary coding on flexible films
- Date / Price / Batch codes
- Language / Ingredients / GDA panels / Nutritional Information
- And many more

### How does SunLase work?

#### Surface Printing

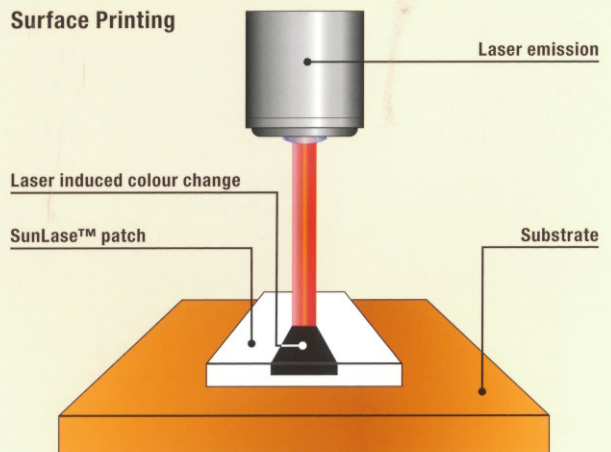

#### Reverse Printing

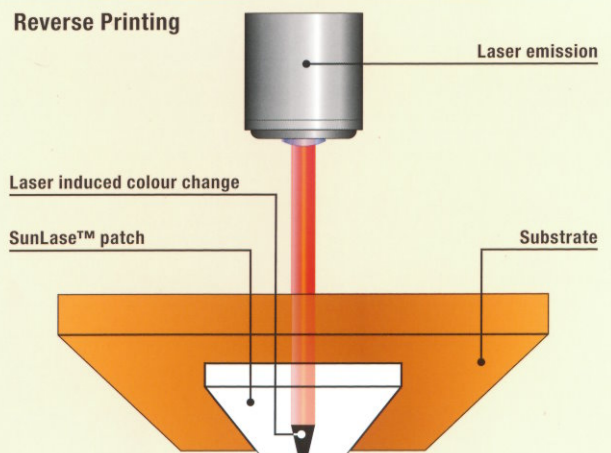

SunLase benefits	Why?	Who benefits?	
<b>PRODUCTIVITY</b>	<b>Reliability</b>	Industrial lasers are robust machines designed for use in demanding environments to minimise unplanned stoppages and maximise performance	PACK CONVERTERS CONTRACT PACKERS BRAND OWNERS
	<b>High speed</b>	Laser coding provides a high quality code faster than the nearest equivalent	PACK CONVERTERS CONTRACT PACKERS
	<b>Repeatability</b>	The laser on the SunLase patch produces a consistent code every single time	CONTRACT PACKERS BRAND OWNERS
	<b>Visual quality</b>	Lasers provide high contrast coding and high level graphics and fonts	BRAND OWNERS
	<b>Flexibility</b>	Marking variable data with the ability to change outputs instantly	PACK CONVERTERS CONTRACT PACKERS BRAND OWNERS
	<b>Space utilisation</b>	Laser marking onto SunLase pre-printed patches enables better defined information to be seen and read clearly	BRAND OWNERS
	<b>Modern process</b>	The latest laser technology enables a controllable minimal power to code and mark substrates that previously would have been damaged	PACK CONVERTERS CONTRACT PACKERS
<b>ENVIRONMENT, SAFETY</b>	<b>Minimal extraction</b>	The SunLase patch causes far less particulates to be produced when laser marked compared to traditional laser ablation	PACK CONVERTERS CONTRACT PACKERS
	<b>Food safety</b>	Thanks to huge reduction of particulates, very little impact on food packaging migration	BRAND OWNERS
	<b>Environmentally friendly</b>	Minimal consumables and nothing secondary is added to the substrate, facilitating easier recycling.	CONTRACT PACKERS
<b>OPERATING COSTS</b>	<b>Minimal consumables</b>	Lasers do not use solvents or ribbons, and allow label elimination	PACK CONVERTERS CONTRACT PACKERS
	<b>Stock Keeping Unit (SKU) reduction</b>	Codes and graphics directly applied to generic packaging stock on an 'as required basis' removes the need for specially pre-printed units	BRAND OWNERS
	<b>Waste reduction</b>	Strong reduction of waste of unused or obsolete promotional packaging thanks to 'print on demand' process	BRAND OWNERS

### Laser Receptive Pigments:

DataLase is a specialist materials company with a portfolio of products and IP in the field of laser receptive pigments. These pigments can be used to create inks, coatings or varnishes that enable a wide range of materials, previously impossible or difficult to mark with a laser, to be receptive to the laser enabling them to be laser coded.

 **DataLase**®

[www.datalase.com](http://www.datalase.com)

### Laser Manufacturers:

For further information about laser manufacturers please contact your local Sun Chemical representative.

## Sun Chemical Overview

Sun Chemical, a member of the DIC group, is the world's largest producer of printing inks and pigments and a leading provider of materials to packaging, publication, coatings, plastics, cosmetics, and other industrial markets including electronic materials, functional and specialty coatings, brand protection and product authentication technologies.

With annual sales over \$4 billion, Sun Chemical has more than 11,000 employees supporting customers around the world. With a network of more than 300 locations in 56 countries, Sun Chemical employees work everyday to meet the needs of customers by improving performance on the essentials of business, such as reliable, on time delivery and consistent product quality. Sun Chemical tailors solutions to unique customer needs and brings new ideas and the latest technology to market. Sun Chemical's unparalleled global presence allows for the delivery of local service and support that is customized to the markets it serves.

Recognized as a leading source of innovation, Sun Chemical has 10 research and development centers that are committed to creating solutions that improve productivity, create new revenue opportunities for customers, and contribute to a more sustainable future. In addition to its leadership in inks and pigments, Sun Chemical introduces new solutions that enable marketers to better manage their brand colors, protect product integrity through improvements in packaging, and introduce security features that defend against counterfeiting.

Sun Chemical also creates innovations for digital printing applications, including inkjet printing systems for narrow web and corrugated printing as well as inkjet inks specifically formulated for LED curing. Sun Chemical Corporation is a subsidiary of Sun Chemical Group B.V., the Netherlands, and is headquartered in Parsippany, New Jersey, U.S.A. For more information, please visit our Web site at [www.sunchemical.com](http://www.sunchemical.com).

Although the information presented here is believed to be reliable, Sun Chemical Limited makes no representation or guarantee to its accuracy, completeness or reliability of the information. All recommendations and suggestions are made without guarantee, since the conditions of use are beyond our control. There is no implied warranty of merchantability or fitness for purpose of the product or products described herein. In no event shall Sun Chemical Limited be liable for damages of any nature arising out of the use or reliance upon the information. Sun Chemical Limited expressly disclaims that the use of any material referenced herein, either alone or in combination with other materials, shall be free of rightful claim of any third party including a claim of infringement. The observance of all legal regulations and patents is the responsibility of the user.

### Sun Chemical Europe

Wexham Springs  
Framewood Road  
Slough, SL3 6PJ  
United Kingdom  
Tel +44 (0) 203 139 0000  
Fax +44 (0) 203 139 0001  
[www.sunchemical.com](http://www.sunchemical.com)

# SunChemical®

a member of the DIC group

